

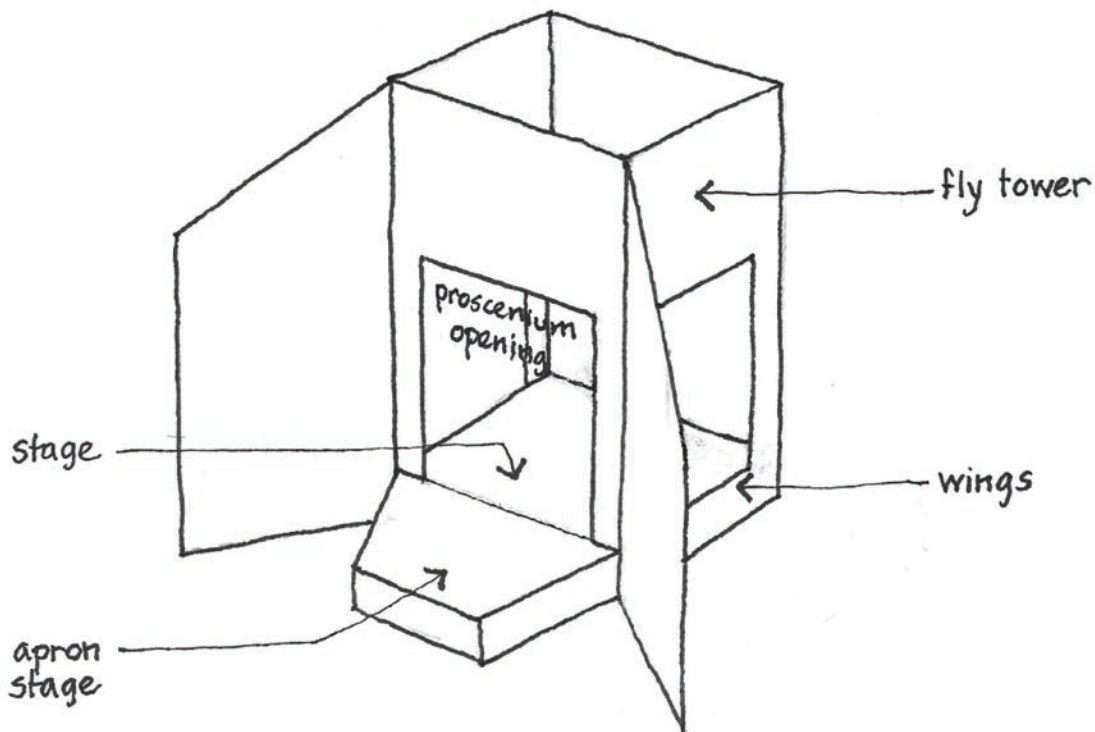

# THE A4 THEATRE

The A4 theatre shown on the following pages consists of a model stage and surrounding structure that you could make to show scenes from William Shakespeare's play 'Romeo and Juliet' or other plays of your choice. It can be made using A4 sheets of card or larger sheets cut to the sizes shown. You could decorate it and make model actors and scenery to place within it as you wish.



The large opening at the front of the stage is known as the 'proscenium opening' and is where the stage curtains usually hang. The spaces on each side of the stage behind the proscenium opening are known as the 'wings'. Usually the actors enter the stage from the wings although sometimes there are entrances at the back and even from within the audience area (the 'auditorium'). During scene changes, sometimes the scenery is lifted into and lowered from a space above the stage, this space being known as a 'fly tower' or 'fly loft'.

# THE A4 THEATRE

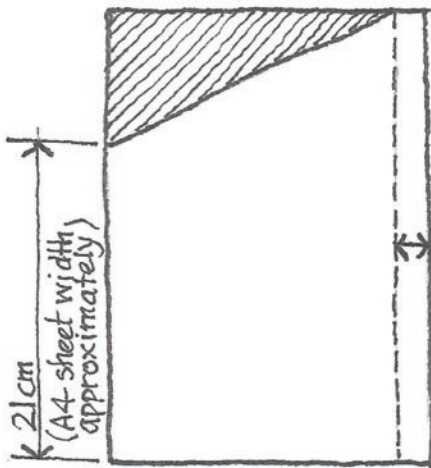

① Auditorium Wall

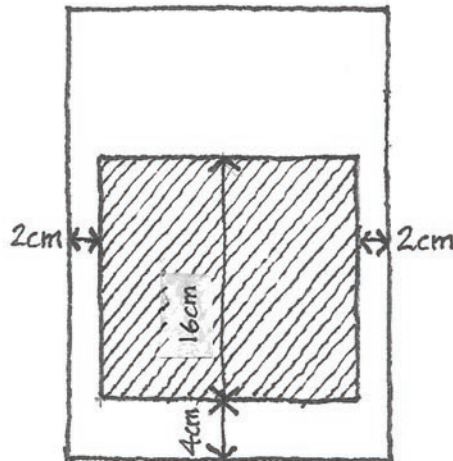

② Stage Front Wall (Proscenium)

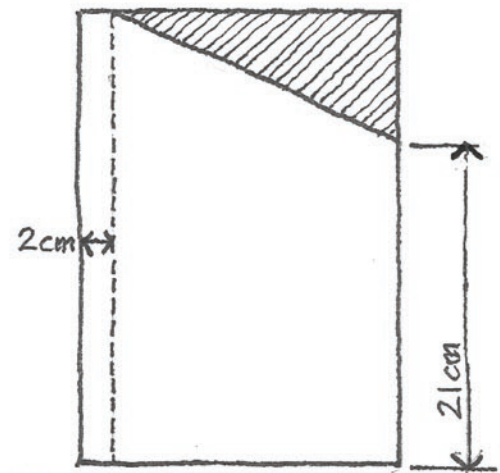

③ Auditorium Wall

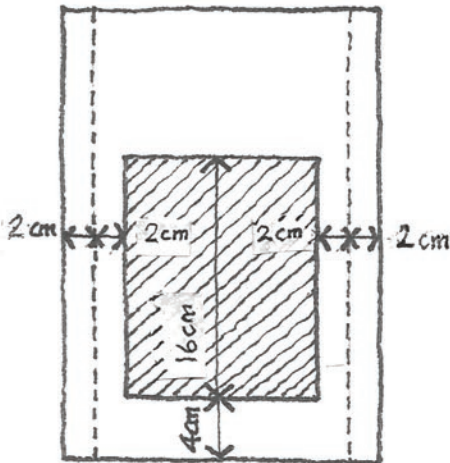

④ Stage side wall



⑤ Wall at back of stage (a full A4 sheet)

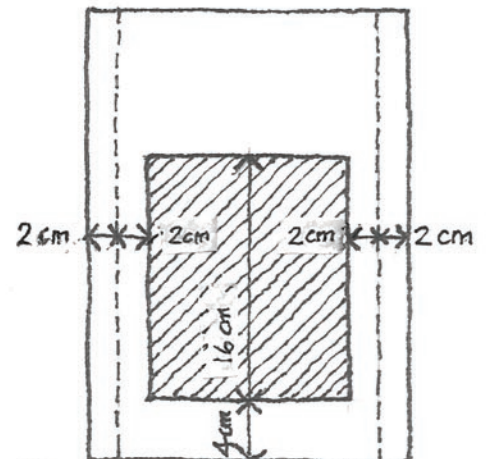

⑥ Stage side wall

This dimension will be a little less than those of the side walls (④ and ⑥) in making allowance for the card thickness. The widths of the fold down edges will be what is left over, around 2cm each side

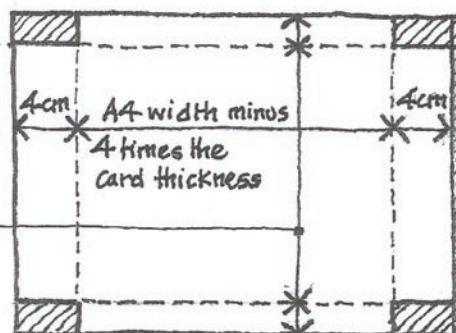

⑦ Stage

A small sliver of card will need to be cut off, how much depending on the width of the stage

These are the parts of a model theatre made from A4 sheets of card. Dimensions shown are in centimetres. Hatched areas are those to be cut off. Broken lines show where the card is to be folded. The folded strips are for gluing to the adjoining sheets. The next page shows how the sheets are put together. It also shows an additional area of stage which projects towards the auditorium in front of the main stage and is known as an 'Apron'. You could make one like this or one of your own choice of shape and size. Larger ones which project further forward are often called 'thrust stages'.

# THE A4 THEATRE

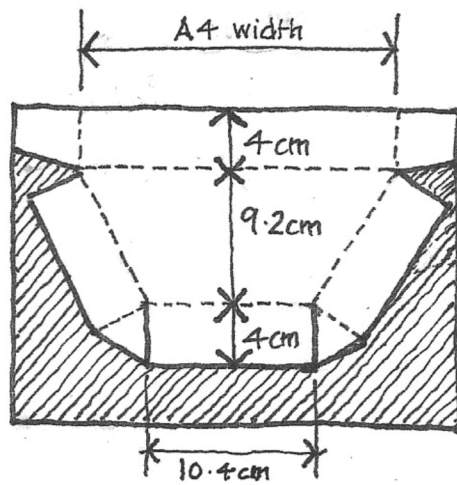
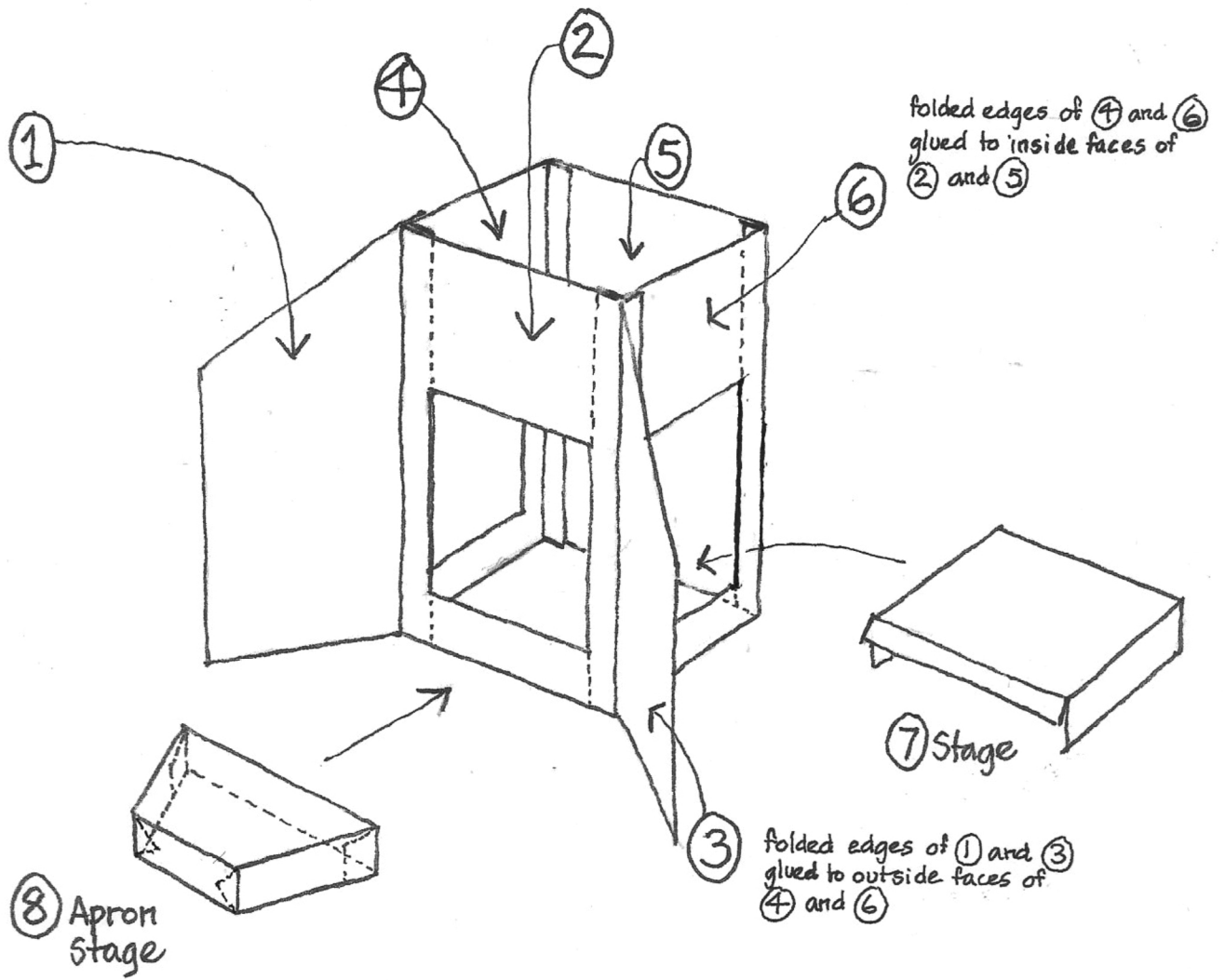

⑧ Apron Stage  
(could be larger and rectangular)

# THE A4 THEATRE

Here is an example using A4 sheets of fairly thin card. It is nice and easy to cut with scissors, but just a little bit floppy. Thicker card, like that used for cereal packets, would help make a stronger structure, but would be more difficult to cut and would require careful scoring in order to make the folds.

